

INSTALLATION MANUAL

CDUN-JD-AN-01

@rehan

Connecting the Units

Note:

- This unit is for vehicles with a 12-volt battery and negative grounding. Before installing it in a recreational vehicle, truck or bus, check the battery voltage.
- To avoid shorts in the electrical system, be sure to disconnect the battery cable before beginning installation.
- Refer to the owner's manual for details on connecting the power amp and other units, then make connections correctly.
- Secure the wiring with cable clamps or adhesive tape. To protect the wiring, wrap adhesive tape around them where they lie against metal parts.
- Route and secure all wiring so it cannot touch any moving parts, such as the gear shift, handbrake and seat rails. Do not route wiring in places that get hot, such as near the heater outlet. If the insulation of the wiring melts or gets torn, there is a danger of the wiring short-circuiting to the vehicle body.
- Don't pass the Yellow lead (power supply) through a hole into the engine compartment to connect to the battery. This will damage the lead insulation and cause a very dangerous short.
- Do not shorten any leads. If you do, the protection circuit may fail to work when it should.
- Never feed power to other equipment by cutting the insulation of the power supply lead of the unit and tapping into the lead. The current capacity of the lead will be exceeded, causing overheating.
- When replacing fuse, be sure to use only fuse of the rating prescribed on this unit and the fuse holder.
- Since a unique BPTL circuit is employed, never wire so the speaker leads are directly grounded or the left and right speaker leads are common.
- Speakers connected to this unit must be high-power types with minimum rating of 50 W and impedance of 4 to 8 ohms. Connecting speakers with output and/or impedance values other than those noted here may result in the speakers catching fire, emitting smoke, or becoming damaged.
- When this product's source is switched ON, a control signal is output through the blue/white lead. Connect to an external power amp's system remote control or the car's Auto-antenna relay control terminal (max. 300 mA 12 V DC). If the car features a glass antenna, connect to the antenna booster power supply terminal.

- When an external power amp is being used with this system, be sure not to connect the blue/white lead to the amp's power terminal. Likewise, do not connect the blue/white lead to the power terminal of the auto-antenna. Such connection could cause excessive current drain and malfunction.
- To avoid short-circuiting, cover the disconnected lead with insulating tape. Especially, insulate the unused speaker leads without fail. There is a possibility of short-circuiting if the leads are not insulated.
- If this unit is installed in a vehicle that does not have an ACC (accessory) position on the ignition switch, the red lead of the unit should be connected to a terminal coupled with ignition switch ON/OFF operations. If this is not done, the vehicle battery may be drained when you are away from the vehicle for several hours. (Fig. 1)



ACC position

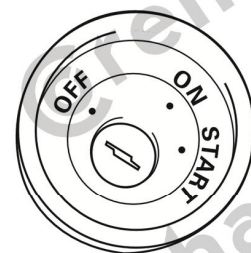

No ACC position

Fig. 1

- The black lead is ground. Please ground this lead separately from the ground of high-current products such as power amps. If you ground the products together and the ground becomes detached, there is a risk of damage to the products or fire.

• Cords for this product and those for other products may be different colors even if they have the same function. When connecting this product to another product, refer to the supplied Installation manuals of both products and connect cords that have the same function.

Connecting the Units

Wire diagram

Before connecting the units, read the wire diagram carefully. Don't mistake the terminal order from power socket. For details of each lead connection, refer to the follow illustrated connection instruction.

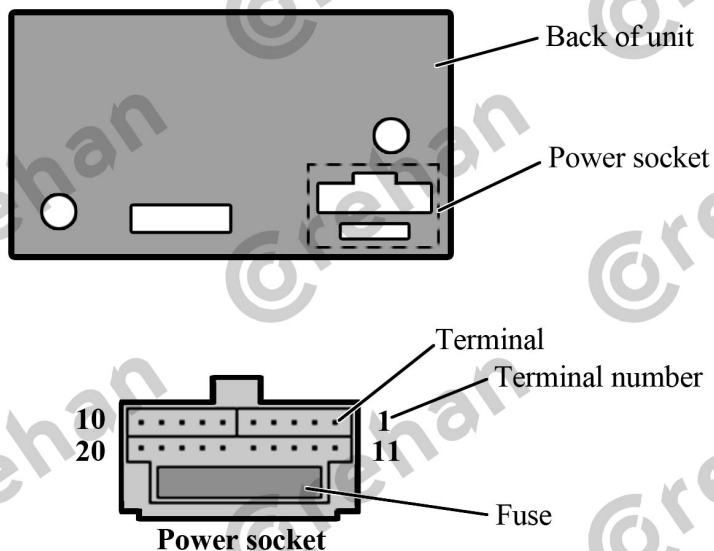

Terminal No.	Usage and wire colour	Terminal No.	Usage and wire colour
1	Side lamp detect(Orange)	11	Canbus-Hwire(Brown+Black)
2	Steering control line 2(Orange+White)	12	Canbus-Lwire(Red+Black)
3	Steering control line 1(Green+White)	13	Antenna control wire(Blue)
4	Amplifer control(Blue+White)	14	Backoff detect(Brown)
5	Parking brake detect(Pink)	15	ACC detect(Red)
6	Front left speaker(+)(White)	16	Front left speaker(-)(White+Black)
7	Rear left speaker (+)(Green)	17	Rear left speaker(-)(Green+Black)
8	Front right speaker(-)(Grey+Black)	18	Front right speaker(+)(Grey)
9	Rear right speaker(-)(Purple+Black)	19	Rear right speaker(+)(Purple)
10	Ground(Black)	20	Power supply+(Yellow)

Connecting the Units

When connecting speakers without using the optional amplifier and subwoofer

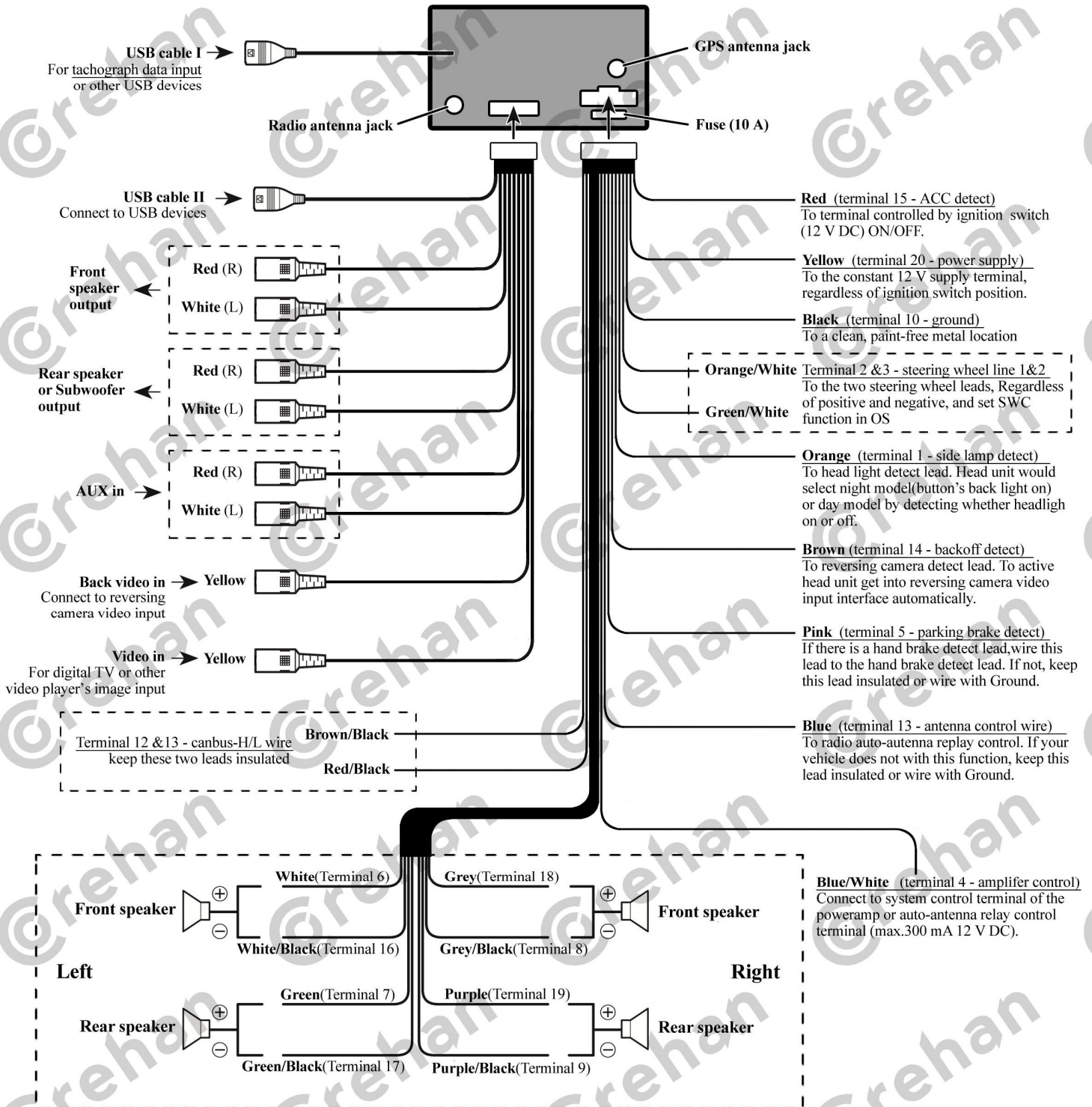

Connecting the Units

When using a subwoofer with the optional amplifier

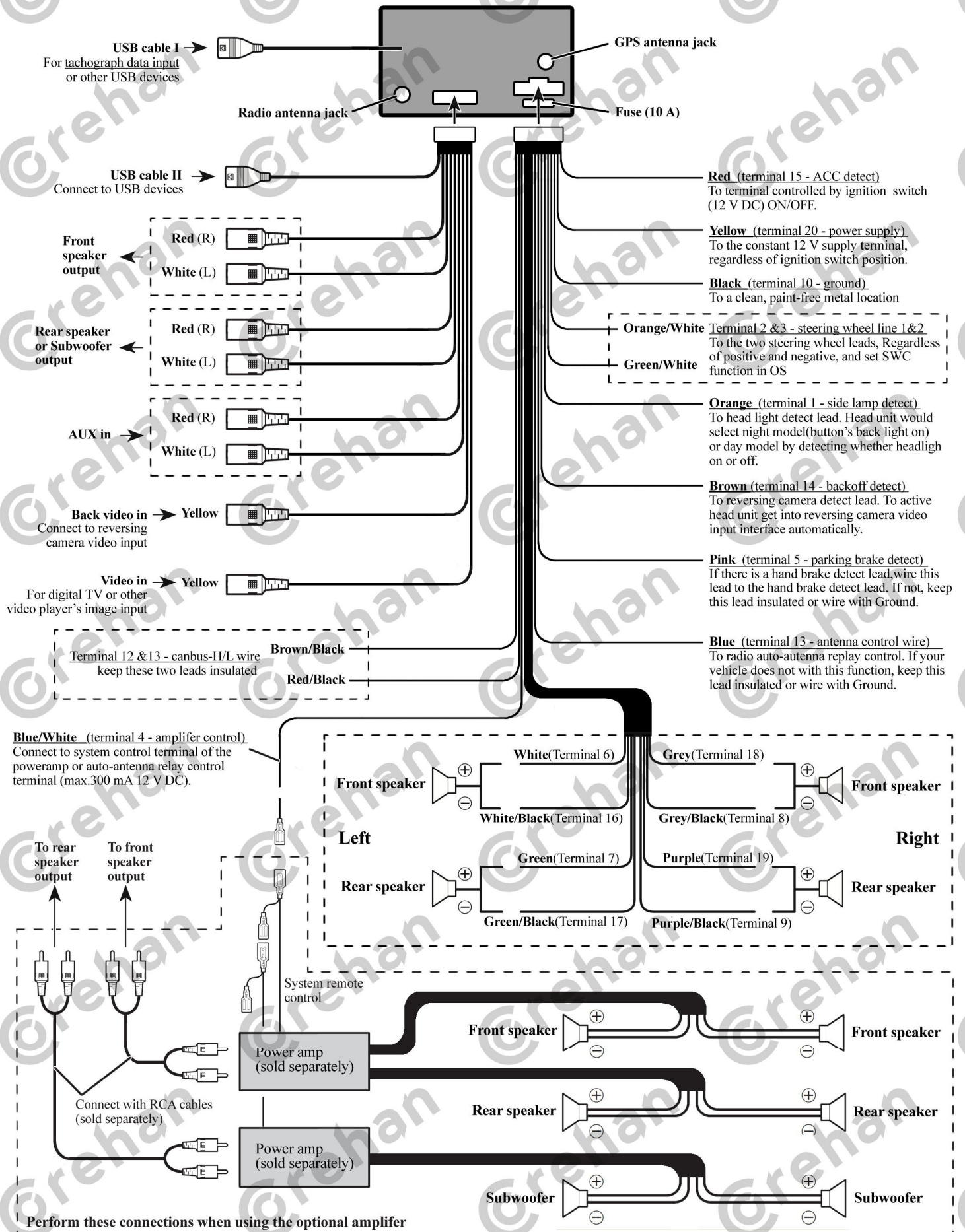

Perform these connections when using the optional amplifier

Installation

Note:

- Before finally installing the unit, connect the wiring temporarily, making sure it is all connected up properly, and the unit and the system work properly.
- Consult with your nearest professional installer if installation requires the drilling of holes or other modifications of the vehicle.
- Install the unit where it does not get in the driver's way and cannot injure the passenger if there is a sudden stop, like an emergency stop.
- The semiconductor laser will be damaged if it overheats, so don't install the unit anywhere hot for instance, near a heater outlet.
- If installation angle exceeds 60° from horizontal, the Head Unit might not give its optimum performance. (Fig. 2)
- When mounting this unit, make sure none of the leads are trapped between this unit and the surrounding metalwork or fittings.
- Do not mount the tuner unit near the heater outlet, where it would be affected by heat, or near the doors, where rainwater might splash onto it.
- Before drilling any mounting holes always check behind where you want to drill the holes. Do not drill into the gas line, brake line, electrical wiring or other important parts.
- If the tuner unit is installed in the passenger compartment, anchor it securely so it does not break free while the car is moving, and cause injury or an accident.
- If the tuner unit is installed under a front seat, make sure it does not obstruct seat movement. Route all leads and cords carefully around the sliding mechanism so they do not get caught or pinched in the mechanism and cause a short circuit.

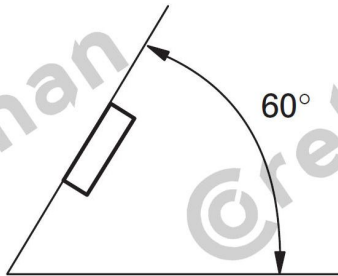
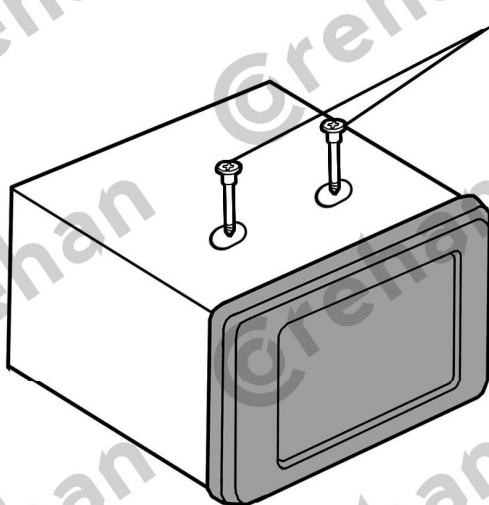

Fig.2

Before installation

Remove the two screws on top of head unit (Fig.3)



Remove these two screws, otherwise the CD/DVD can not insert the CD driver.

Fig.3

Installation

DIN Rear-mount

This unit can be properly installed “Rear” (DIN Rear-mount installation, utilizing threaded screw holes at the sides of unit chassis). For details, refer to the following illustrated installation methods.

DIN Rear-mount

Installation using the screw holes on the side of the unit

1. Purchase a dash kit with mounting bracket from after market.

- Before you purchase, make sure the dash kit’s size fits for your vehicle model, and install with double din head unit.

2. Fastening the unit to the radio mounting bracket. (Fig.4)(Fig.5)

- Select a position where the screw holes of the bracket and the screw holes of the head unit become aligned (are fitted), and tighten the screws at 2 places on each side, depending on the shape of the screw holes in the bracket. The screw length depends on the thickness of mounting bracket.

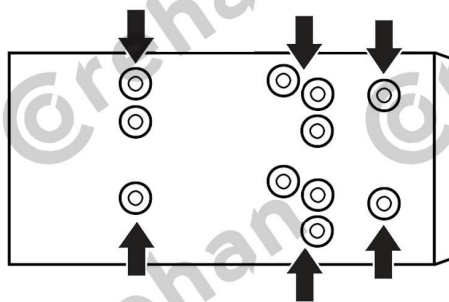

Fig.4

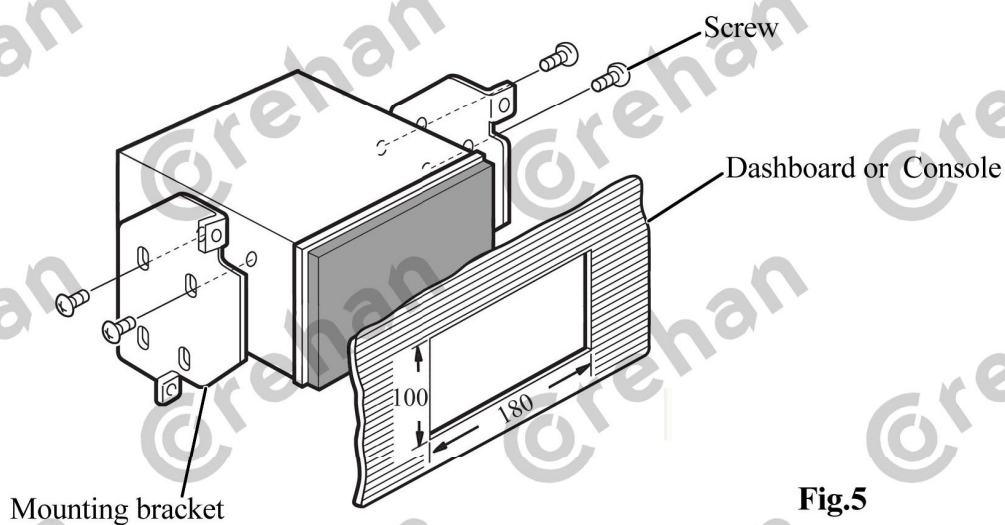

Fig.5

Steering wheel control

Steering wheel control setting

Steering wheel control function is still unavailable, only if set the function on head unit. For details, refer to the following illustrated setting method.

1. Power up the head unit, click into “Apps” on desk, find the app ”steering wheel ” (Fig.6)and open it(Fig.7).
2. Click the button “START” that turns into “END” and yellow color.
3. Press and hold the button you are going to program from steering wheel, and click the function you are going to set on screen, such as “VOL+”
4. The program setting successful until button “VOL+” turns into grey.
5. Set the other buttons from steering wheel according to the same method.
6. Click the button “END” to finish the setting

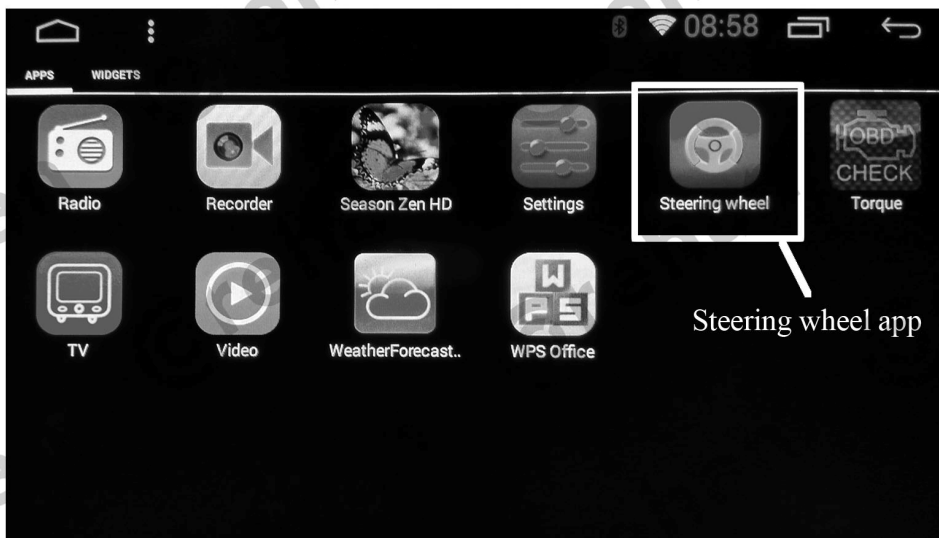

Fig.6

VOL+	VOL-	MUTE	MODE
HOME	MENU	BACK	NEXT
PREV	ANSWER	POWER	NAVI
RADIO	EJECT	BUTTON	DISC
RESERVE	RESERVE	RESERVE	RESERVE
START	RESERVE	RESERVE	CLEAR

Fig.7

If you have any questions or problems in installation or head unit operations, please log in our official website:

www.corehan.com

to find your answer from Troubleshooting section, or FAQ section in the head unit model description page.

Also you can contact us for technical support by email us:

service.amazon@corehan.com

or leave us message via the message box in our official website.